

## MONITORING AND DECISION SUPPORT SYSTEMS FOR IMPACTS MINIMIZATION OF DESALINATION PLANT OUTFALL IN MARINE ECOSYSTEMS.

Jose M. Hernandez Torres <sup>a</sup>, Aina Hernandez Mascarell <sup>a</sup>, Marta Navarro Hernandez <sup>a</sup>, Miguel Martin Monerris <sup>c</sup>,  
Rafael Molina <sup>b</sup>, Jose M. Cortes <sup>d</sup>.

<sup>a</sup> Tecnomas S. A. C/ Antiga senda de Senent, 11-33<sup>a</sup> - 46023. Valencia, SPAIN.

Ph.: +34+96 337 92 20. Fax: +34 96 337 14 29. e-mail: [jhernandez@tecnoma.es](mailto:jhernandez@tecnoma.es)

<sup>b</sup> Typsa. Gomera 9, San Sebastián de los Reyes – 28700. Madrid. SPAIN.

Ph.: +34 91 722 73 00. Fax: +34 91 6517588. e-mail: [rmolina@typsa.es](mailto:rmolina@typsa.es)

<sup>c</sup> Department of Hydraulic and Environmental Engineering, Polytechnic University of Valencia.  
Camino de Vera, s/n. – 46022. Valencia, SPAIN.

Ph.: +34 96 387 70 07. e-mail: [mmartin@hma.upv.es](mailto:mmartin@hma.upv.es)

<sup>d</sup> SIDMAR Bernhard Pack S.L. Avda. País Valenciano, 22, E-03720 BENISSA (ALICANTE), SPAIN

Ph. +34 965731073; Fax: +34 965731106; e-mail: [jcortes@sidmar.es](mailto:jcortes@sidmar.es)

### ABSTRACT

ASDECO is a R&D project whose main objective is to design a system that allows for the implementation of Adaptive Management for brine discharges from desalination plants into the sea. The project phases has two phases: to design and the adapt the instrumental system to the characteristics of the brine plume, achieving the required reliability and precision. An information and forecast system has also been constructed to compile and validate the data, as well as to activate the alarm protocols required for the Environmental Impact Declarations. The application of forecast systems will provide the outfall management with the necessary flexibility to adapt to the favourable conditions of the marine environment, maximizing dilution and minimizing brine impact. The system is currently being implemented and tested in the Alicante Channel desalination plant (Alicante – Spain).

### Keywords

ASDECO, brine discharge, brine plumes, Ocean-meteorological Data Acquisition System, Brine Dispersion Forecast System, Support tool for decision making, Adaptive Management.

### INTRODUCTION

The development of Sea Water Desalination Plants (SWDP) for urban supply and agricultural purposes in different areas of Spain has increase greatly in recent years as a way of lessening the scarcity of the resource. There are currently 900 desalination plants in Spain, which have an installed capacity that is greater than 1.5 Hm<sup>3</sup>/day [2]. This capacity will be exceeded through the upcoming implementation of more than 34 desalination plants that are currently in different phases of development and that will add around 700 Hm<sup>3</sup>/year to the existing production (140 Hm<sup>3</sup>/year – 2004).

From an environmental point of view, desalination has two main problems: energy consumption and waste discharge management where brine is the main component [6]. When the raw water is taken from the sea, the effluent salinity can increase between 10% and 70%, depending on the technology used [2]. In the case of effluent discharge into the sea, and especially in the presence of communities of particular biological interest (as is the case with the marine phanerogam grasslands that have a poor tolerance to increases in salinity [1]), outfall management should be carried out based on the principles of caution and sustainability. In order to achieve appropriate discharge management, we must increase our knowledge and provide the authorities and the entities that are developing and managing the installations with appropriate tools to improve discharge efficiency and to increase the effectiveness of brine dilution into the sea.

The implementation of many of the abovementioned desalination projects requires the authorities to meet the requirements of the Environmental Impact Declaration (EID), which involve strict monitoring programmes that activate protocols for the periodic stoppage of the plant mainly by the activation of alarms when the salinity values are exceeded in the protection perimeters of the most vulnerable biological elements. There are still many brine

discharge declarations to be issued by authorities that should specify the uncertainties associated to the EID for desalination plants, which must then be applied.

TECNOMA, in collaboration with SIDMAR, is developing the ASDECO Project (Automated System for Desalination Dilution Control. [www.proyectoasdeco.com](http://www.proyectoasdeco.com)). This research is subsidized within the National Programme of Environmental Science and Technology of the National R&D Plant 2004-2007 and is coordinated by the Ministry of the Environment and Rural and Marine Affairs.

This applied research project aims to create a prototype that adapts and improves the control of desalination plant discharges in the marine environment. The goal is to combine the capacity of Decision Support Systems (DSS) and the latest instrument innovations. As a pilot case for the development of the system, we are currently implementing the prototype at the Alicante Channel Desalination Plant, thanks to the collaboration of the Canales del Taibilla Association.

## OBJECTIVES

The high variability of marine conditions each year means that sustainable and efficient management of the outfall must be available for these conditions. At present, there are few options that offer control and adaptation tools in the ordinary management of brine discharge into the marine environment. Therefore, the main objective of ASDECO is to develop a prototype that provides this capacity in the following ways:

- Improve operation control: Supervise the correct operation of the plant and the brine discharge and corroborate compliance with the Environmental Impact Declarations and outfall authorization. Have a real-time time monitoring system that enables awareness of the behaviour of the discharge.
- Adaptation: Avoid rigid discharge management by adapting to the conditions of the receiving environment. A sustainable management strategy would be based on maximizing the dilution of the waste in the most unfavourable conditions and minimizing it when the conditions allow, given its lesser impact on the environment (maximum turbulence conditions).

The main purpose of ASDECO is to offer this adaptation in the ordinary management of the desalination plant outfall. In order to do this, a tool has been designed to provide information in real time about the conditions of the receiving medium. It uses this information to predict the behaviour of the hypersaline plume, which will allow **Adaptive Management** to be implemented in the desalination plant. The prototype developed can also be used as a powerful alarm and information tool for development authorities, the developing authorities and the companies operating the installation, and the pertinent environmental authorities.

The ASDECO System uses real-time analysis of ocean-meteorological data from the marine environment and the effluent in order to optimize the marine environment mixing capacity to maximize the efficiency of the outfall system, without harming the marine ecosystems. In the case of ocean-meteorological conditions that favour dilution, the system could help to optimize the operational cost by acting on the pumping capacity of the dilution water or reducing the pressure in the discharge outlet diffusers.

## ASDECO PHASES

ASDECO has been developed in the following phases:

- a. Design and integration of the instrumentation.
- b. Development of an Alarm and Information System.
- c. Development of a Decision Support System (DSS).
- d. Integration of the system into the Ordinary Management of a pilot installation.

a. Design and integration of the instrumentation. In this first phase, a prototype of the ocean-meteorological data acquisition station was designed with data that was as the characteristics of the discharge of desalination plant effluent, as well as the characteristics of control of the hypersaline plumes in the marine environment. The plants were optimized for plume control, both in near field and far field. The aim of this optimization was to adapt

its components and provide them with the necessary precision and reliability requirements. The basic objective was to design a compact and reliable solution that allows the integration of a large number of sensors: CTD, current, wind, and wave height profilers, and water quality (dissolved oxygen, temperature, turbidity, redox, chlorophyll a, green algae, etc).

The prototype design allows for the integration of additional functions such as the following selection of buoys that house all of the components; the optimization of a mooring system; the energy system; the incorporation of a positioning system in case of loss to help determine the drift; the incorporation of multiple communication systems (GSM, radio, WIMAX, Satellite).

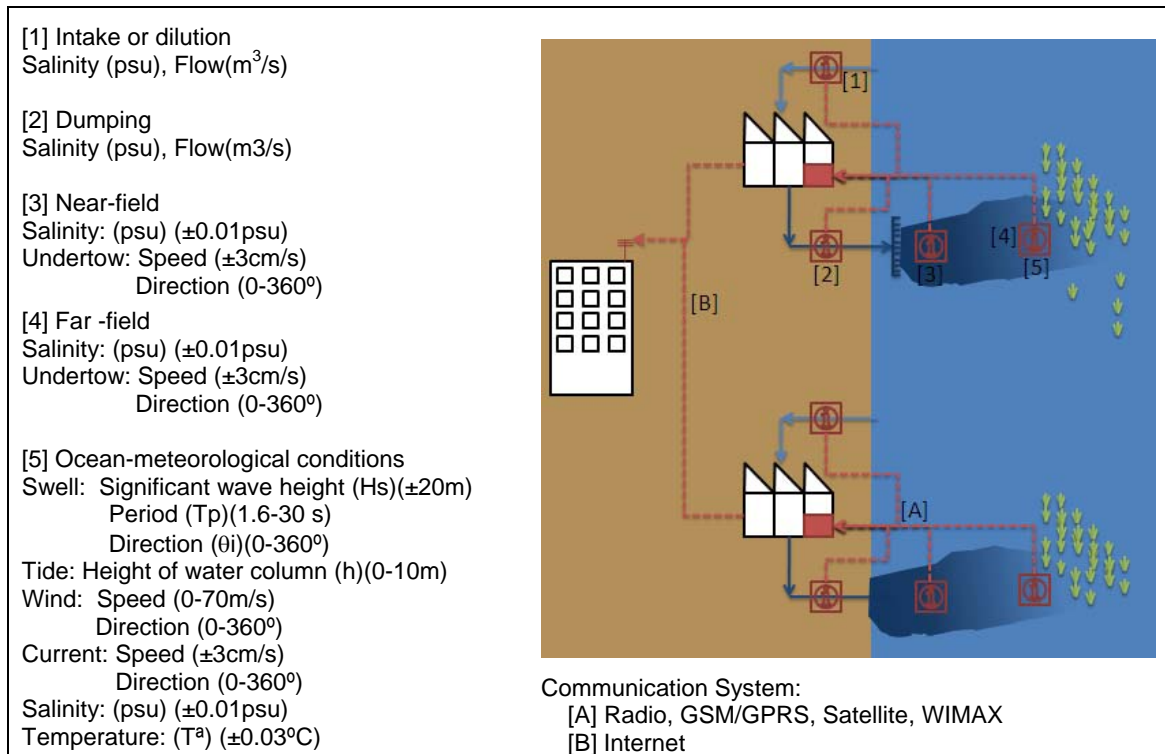

Figure 1.- Outline of the implementation of sensors and communications.

b. Development of an Alarm and Information System. The information system allows the information that is acquired in real time by multiple systems to be recompiled and validated. This is done by incorporating an error identification protocol, testing the state of the instrumentation, and facilitating its analysis. The Information System uses a corporate database that is based on SQL and is integrated with a GIS viewer that displays cartographic, vectorial and raster information associated to each desalination plant. This information system generates automated reports in an easy-to-use web environment, providing development authorities the necessary tools for early control and vigilance of the desalination plants. This tool can be shared with environmental agencies or be made available to the public.

This management and supervision tool is designed to centrally recompile and monitor brine discharge in several plants. The generation of alarms is especially useful when certain salinity threshold values are exceeded over certain periods of time (exceedance percentile) (Figure 2) [1]. These thresholds can define several action levels (alarm level, emergency level, etc.) in accordance with the criteria defined in the EID or in the discharge authorization. The system has a communication module that informs of the alarm activation via email or SMS.

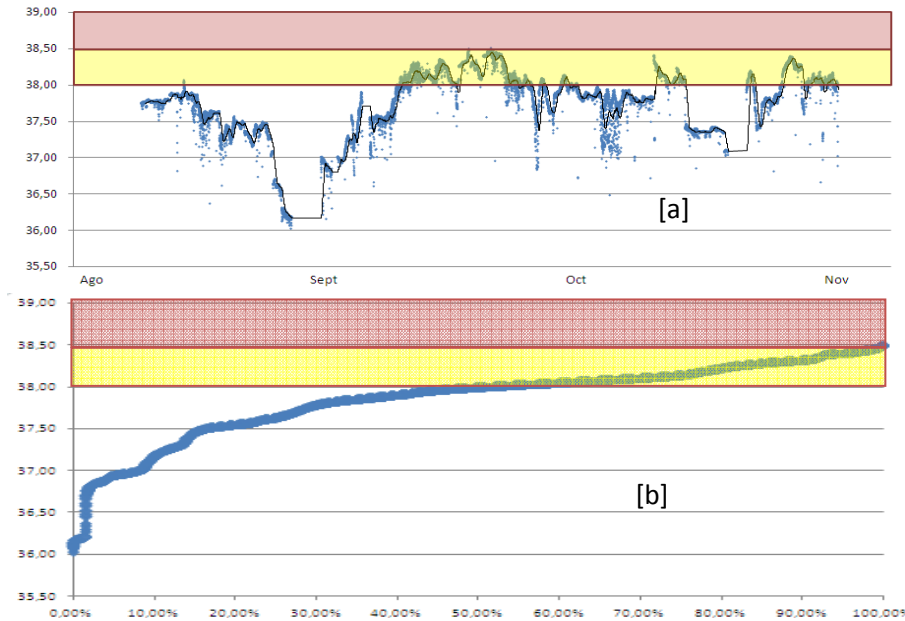

Figure 2.- Evolution of observed salinity (psu) every 5min at a depth of 20cm in a monitoring CTD of a brine dump and alarm levels [a]. Non-exceedance percentile during the time of the observations in September [b].

c. Development of a Decision Support System (DSS). This phase is mainly dedicated to the production of a decision tool that analyzes the instant and seasonal operation of the brine discharge. This tool provides management measures to maximize the brine dilution and thus reduce its impact on the receiving medium. The core of the tool is based on a forecast module that uses a combination of fuzzy logic and neural networks to forecast the distribution of the plume and predict salinity levels in the protection perimeters. The use of neural networks associated to oceanographic forecasts has been extensively used [4] [5]; however, their combination with fuzzy logic techniques are very recent, for example those associated with predicting the ecological state of continental surface water bodies [8] or the analysis of reservoir water quality [7].

This forecast system makes use of the instrumental network implemented to train and validate the neural network in such a way that, at a monitoring point, the salinity will depend on the ocean-meteorological conditions of the marine environment and the flow and salinity of the desalination plant discharge (see Figure 3). The forecast system will also be connected to the operation networks of the National Sea Port System to correlate their climatic forecasts with the brine discharge environment (6, 12, 24 and 48 hours). This facilitates Adaptive Management by providing feed back data to the predictive system.

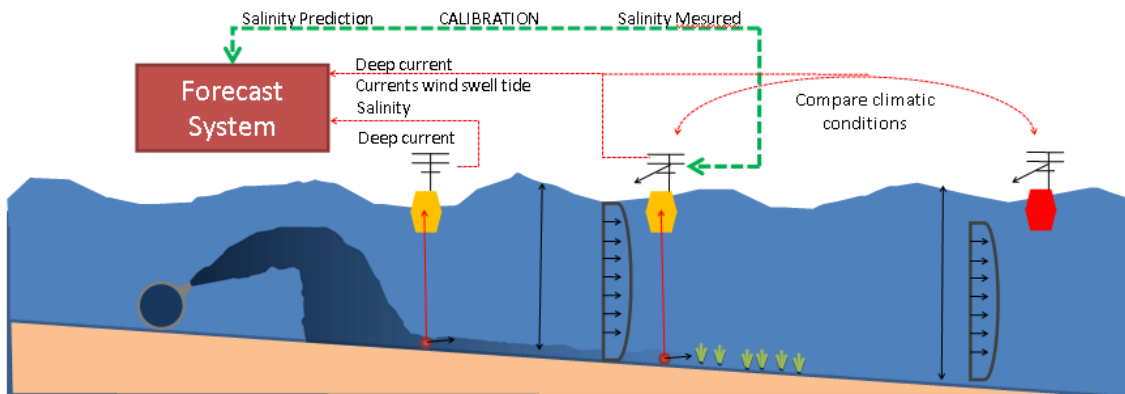

Figure 3.- Outline of the interaction of the sensors and the forecast system during training, calibration and validation.

The system focuses on two fundamental management scenarios:

1. The first of these is to detect salinity values in the near field that could be potentially transported to the protection perimeter (Figure 4). The forecast tool continuously evaluates the salinity values, the outfall, the bottom salinity conditions in near-field, and the conditions at the edge of the marine environment. When necessary alternative management of the outfall is proposed to avoid possible disruption (e.g. increase the planned dilution, increase the number of outlets, or increase the outflow speed).

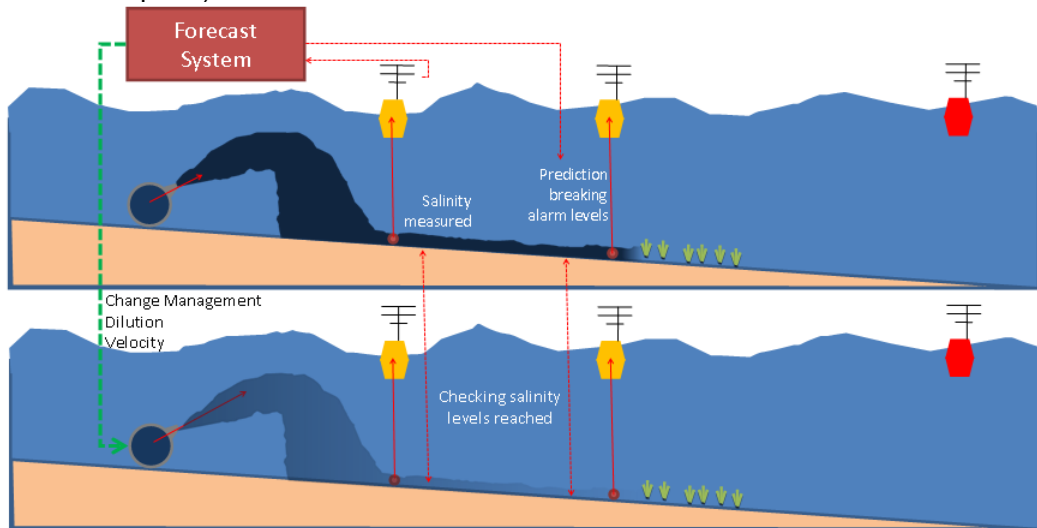

Figure 4.- Conceptual outline of the Adaptive Management operation in forecasting disruptions.

2. The second of these is linked with the maritime climate, which implies changes in the energy state of the sea and, therefore, in the dilution efficiency of the plume in both near-field and far-field. A very useful management protocol might be to link the outfall management and progress over time. This would not only prevent possible disruptions caused by low energy (Figure 5), but it would also make use of greater turbulence scenarios, which allows plume dilution.

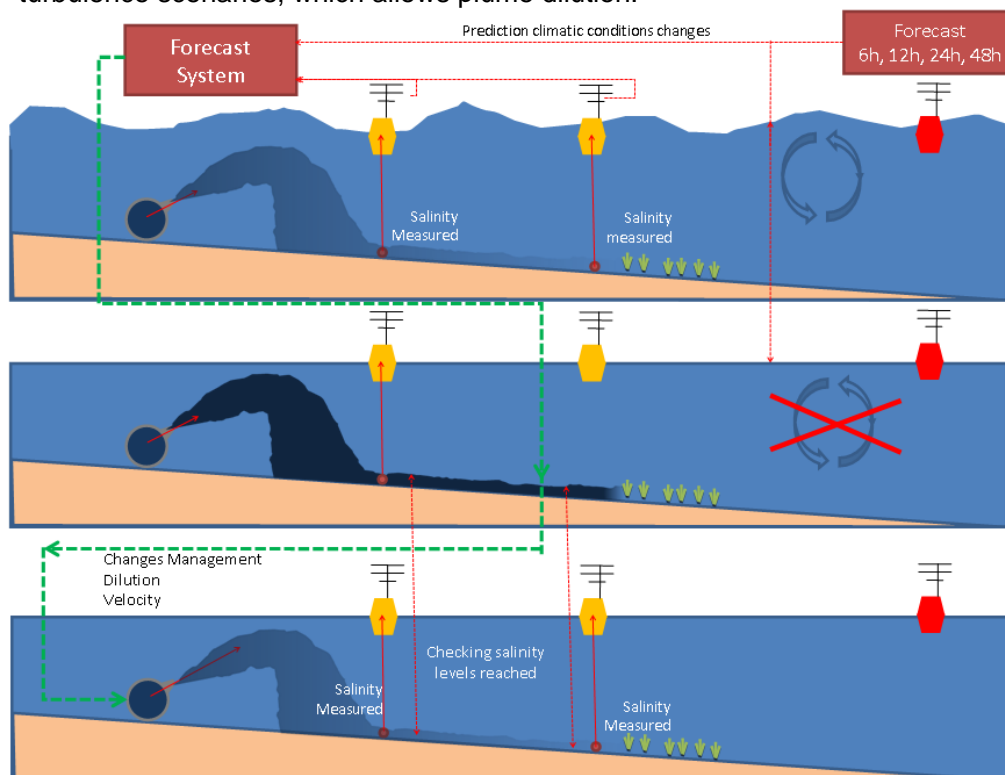

Figure 5.- Conceptual outline of the Adaptive Management operation in forecasting climatic changes.

d. Integration of the pilot system into ordinary management. The pilot system has been integrated into the Alicante Channel desalination plant. The desalination plant has a treatment capacity of 130.000 m<sup>3</sup>/day. It is currently in operation to provide drinking water to the metropolitan area of Alicante City. This area on the coast of Spain has a large tourist sector and is characterized by a water deficit. Desalination is one of the greatest structural solutions developed to alleviate the region's deficit, even though the sustainability, of the area requires preserving the great wealth of the marine environment (e.g. marine phanerogam grasslands as a prime example).

The Alicante Channel desalination plant carries out its dumping on the surface of the coastline which generally has a dilution of 1:2. The discharge generates an average flow of 7 m<sup>3</sup>/s and a salinity of 50 psu. This discharge is currently the object of an intensive monitoring programme due to the existence of phanerogam grasslands that are located approximately 1.6 km in front of the discharge point (Figure 6).



Figure 6.-Location of details of the Alicante Channel desalination plant.

The integration of this pilot system consist of the installation of an Acquisition System for Oceanographic Data in near-field and far-field, including this characterization of the specific conditions of the brine discharge. The buoys and data acquisition instrumentation are complemented with a CTD field due to the characteristics of the seabed. There are multiple preference channels, which allow for the diffusion of the plume in more than one main direction depending on the marine conditions. With this information a spatial campaign was carried out to characterize the plume distribution. This data will not only provides knowledge about the plume behaviour, but it also provides a large number of records for the training and validation of the forecast system. The pilot installation and integration of the system has been underway since November 2008, and the implementation of the first system validation, has been completed (previous data was acquired by the EID monitoring plan). These first results indicate the great influence of the maximum wave height in the dispersion of the brine plume. With regard to the calibration of the forecast system, some favourable adjustments have been obtained with R<sup>2</sup> greater than 0.80 (Figure 7).

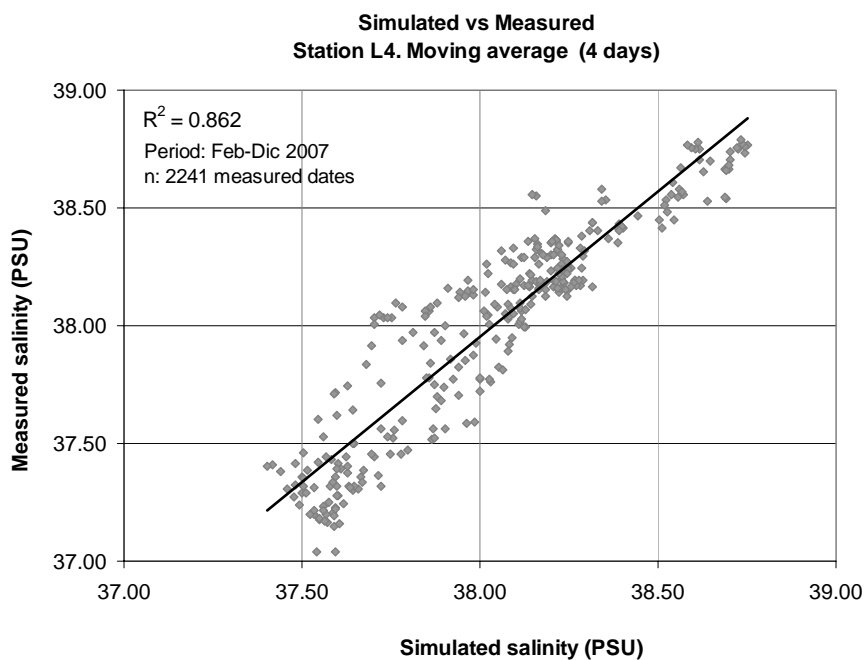
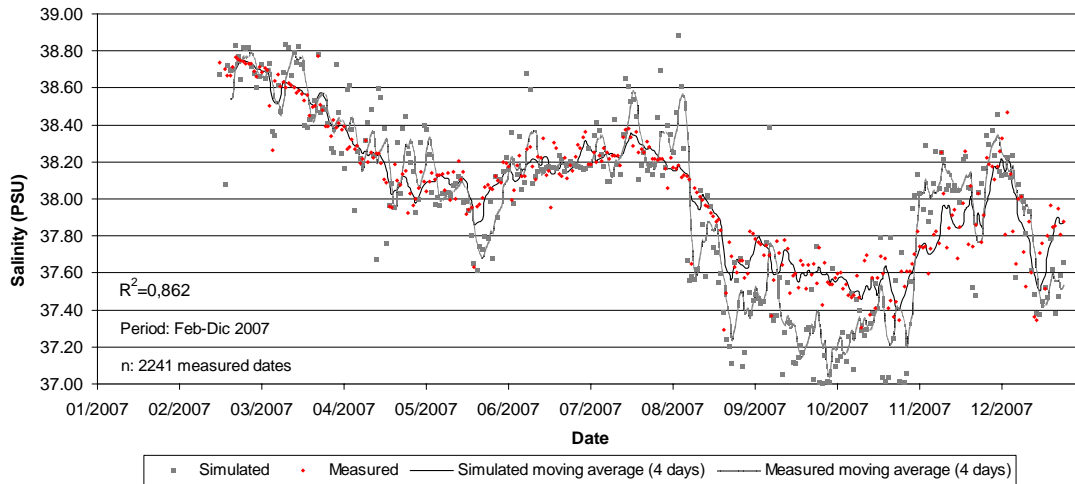

Figure 7.- Time series comparison and measured and predicted value analysis for a control station in *Posidonia oceanica* edge.

## CONCLUSIONS

The ASDECO R&D project is close to achieving the complete development of an entire system that allows the implementation of Adaptive Management in brine discharges from desalination plants into the sea. Great effort has been made to adapt the most recent and innovative sensors to the system monitoring capacities. The integration of this real-time acquisition system with a Brine Dispersion Forecast Tool represents a great technical advance in creating a complete Decision Support Tool that achieves adaptative brine outfall management.

The pilot implementation shows that the use of neural diffuse types such as ANFIS can be an acceptable initial option for the follow-up and control of waste brine into the sea (at least, until the deterministic models finally adjust correctly to the turbulent dispersion processes in the problem of transport and brine dispersion), computational requirements are adjusted for real-time applications. The increasing trend in salinity is due to the increase in salt load and, the decrease in maximum wave height. It is worth mentioning that the maximum wave height does not explain the average dispersion condition of the plume in the sea nor the occasional decrease peaks of salinity: for prolonged periods of calm, the salinity increase

with respect to the salinity base values is high, while for relevant wave height, the plume undergoes more dispersion.

## REFERENCES

- [1] Fernández-Torquemada, Y.; Sánchez-Lizaso, J.L.; González-Correa, J.M. 2005. Preliminary results of the monitoring of the brine discharge produced by the SWRO desalination plant of Alicante (Spain). *Desalination*. 182 (2005), 395-402.
- [2] Ruiz-Mateo, A. 2007. Los vertidos al mar de las plantas desaladoras. Centro de Estudios de Puertos y Costas. Ministerio de Fomento. Ministerio de Medio Ambiente. *Ambienta, Revista del Ministerio de Medio Ambiente*, 62, 51-57.
- [3] Sánchez-Lizaso, J.L.; Romero, J.; Ruiz, J.; Garcia, E.; Buceta, J.L.; Invers, O.; Fernández-Torquemada, Y.; Mas, J.; Ruiz-Mateo, A.; Manzanera, M. 2007. Salinity tolerance of the Mediterranean seagrass *Posidonia oceanica*: recommendations to minimize the impact of brine discharges from desalination plants. *Desalination* 221 (2008), 602-607.
- [4] Medina, J.R., 2004, "Improving wave predictions with artificial neural networks, by O. Makarynsky", *Ocean Engineering*, vol. 32, no. 1, pp. 101-103.
- [5] Mandal, et Al. 2008. Application of Neural Networks in Coastal Engineering – an overview. The 12th International Conference of International Association for Computer Methods and Advances in Geomechanics (IACMAG).
- [6] Meerganz von Medeazza, G.L. 2005. Direct and socially-induced environmental impacts of desalination. *Desalination*. 185 (2005), 57-70.
- [7] Marce, R. et Al. A neuro-fuzzy modeling tool to estimate fluvial nutrient loads in watersheds under time-varying human impact. *Limnology and Oceanography: Methods* 2, 2004, 342–355
- [8] Ocampo-Duque, W et Al. 2007. A neural-fuzzy approach to classify the ecological status in surface waters. *Environmental Pollution* 148, 2007, 634-641.